

INSTALLATION INSTRUCTIONS

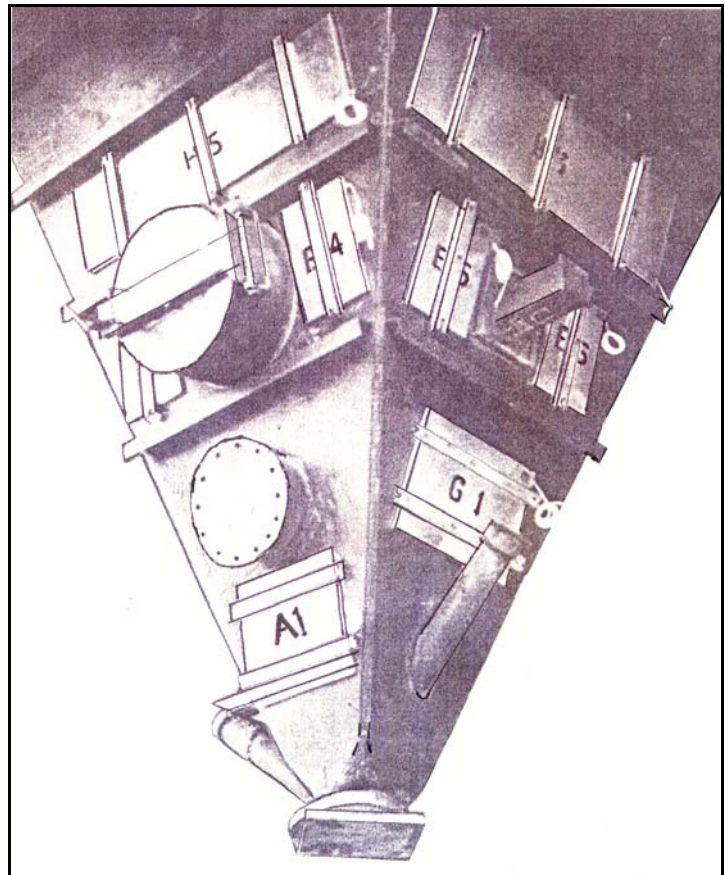

**FLYASH HOPPER
HEATING
SYSTEMS**



When installed in accordance with the National Electrical Code.



When installed in accordance with the Canadian Electric Code

INTRODUCTION

Type HB Heating Modules and Systems are custom designed to fit the configuration of the hopper to be heated. A *basic* system will consist of heating modules, aluminum mounting channels, mounting studs, nuts and washers. Flexible throat heaters to fit cylindrical throat outlets or poke tubes may also be part of the system design. Optional accessories such as Power Junction Boxes, Thermostats, Control and Monitoring Panels and Distribution Panels are all available to provide a package design to meet the needs of each client, application and budget.

The following instructions are guidelines for the installation of a *basic* HB Heating Module System. *Before commencing any installation, the installer must also consult the Heating System Layout drawings, Wiring Diagrams and Operation and Maintenance Manuals supplied by HTD Heat Trace on every project.*

STORAGE AND HANDLING

Individual HB Heating Modules and / or systems must be stored indoors in dry, clean conditions in their original shipping carton(s) until the installer is ready to commence the actual installation.

HB Heating Module Systems are normally packed and shipped in their own individual shipping and storage carton, such that each system can be taken directly to the hopper and installed. Remaining systems should be left in storage until needed. Any heating modules that cannot be installed by the end of the working day should be returned to their shipping carton and placed back into storage until needed.

Do not leave any heating modules (either installed or un-installed) outdoors without adequate climatic protection.

PRELIMINARY STEPS

Compare the Heating System Layout drawing to the actual hopper. Ensure that all hopper accessories/appurtenances such as manways, poke tubes, strike plates, fluidizers, etc. are all physically located as shown on the Heating System Layout drawing. Also ensure that there are no additional hopper accessories or appurtenances that will interfere with the HB Heating Module locations as shown on the Heating System Layout drawing.

Identify the location for the Power Junction Box. At this time (if this optional accessory has been purchased as part of the HB system), weld the Power Junction Box Mounting Bracket into the position shown on the Heating System Layout drawing. All HB Heating Modules and their custom cold lead cable lengths are oriented to the location of the Power Junction Box. *If the Power Junction Box cannot be located in the exact position shown on the Heating System Layout drawing, please contact HTD before proceeding with the installation.*

Use the Heating System Layout drawing to provisionally identify the location of each heating module on the hopper. Most HB Heating Modules are positioned horizontally or vertically in the zone being heated. At this stage of the installation, it is useful to mark each area of the hopper to show the centerline of the module being installed and the module designation letter shown on the drawing. Chalked centerlines for horizontally installed modules are normally midway between hopper stiffeners and the centerline for vertically installed modules is frequently the centerline of the hopper.

Identify the aluminum mounting channels and (when applicable) the stud location templates that are to be used with each size and location of heating module. Mounting channels are marked with the same letter designation as the module they are to be used with. Likewise, stud location templates are also marked with the same letter designation of the module they are to be used with.

**HB HEATING MODULE
MOUNTING PROCEDURE**

The Heating System Layout drawing shows the number of mounting channels to be used with each size of heating module and their orientation.

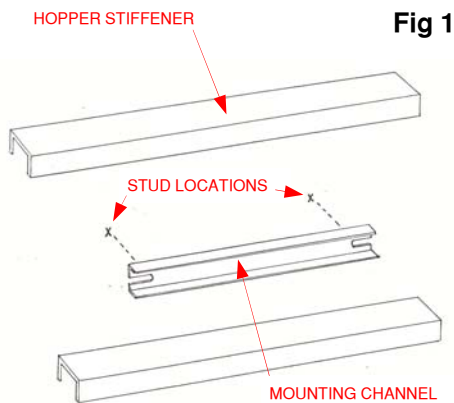

Fig 1

To locate the mounting stud positions for any HB Heating Module that uses ONE mounting channel, the installer uses the actual mounting channel as a template to pinpoint and mark the two stud locations on the hopper surface (**Fig 1**).

HB Heating Modules that require TWO or MORE mounting channels are supplied with a specific template that will pinpoint the location of the four (or more) studs to be used.

Always centralize the mounting channel or template within the hopper plate area being heated before marking the stud locations (**Fig 1**).

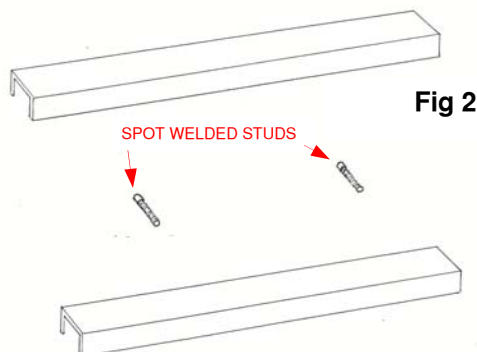

Fig 2

Wipe the hopper surface to remove any moisture, dust, rust or foreign material that may impede the stud welding process or the installation of the HB Heating Module.

Securely spot weld one mounting stud at each of the marked locations (**Fig 2**).

Each stud is 3½ inches long by 3/8 inches diameter and each stud is supplied with two nuts and one washer.

Studs should be spot welded to the hopper surface using a capacitor discharge or full weld type spot welding machine.

HB HEATING MODULE

INSTALLATION INSTRUCTIONS

Fig 3

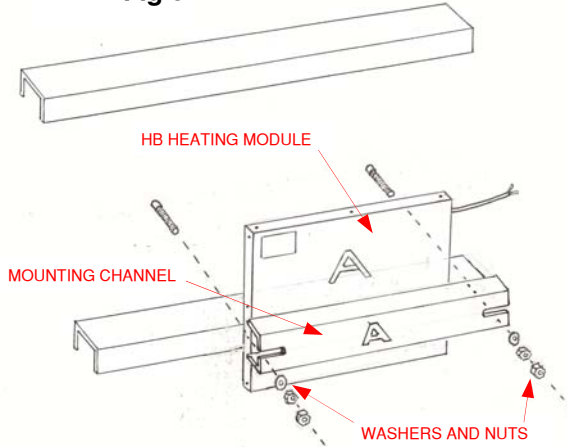

Wipe the hopper surface to remove all moisture, dirt / dust. Offer the HB Heating Module up to the hopper with the gray siliconized glasscloth heater face towards the hopper surface. The heating module must be oriented with the cold lead cable exiting to the correct side of the hopper, as shown on the Heating System Layout drawing. Failure to orient the heating module correctly will result in incorrect routing of the cold lead cable, which, in turn, may result in the cable being too short to reach the Power Junction Box.

Place the aluminum mounting channel(s) over the studs and the back face of the HB Heating Module (**Fig 3**). *Each mounting channel must be installed with the two flanged edges in contact with the back face of the HB Heating Module as shown in Fig 3.* Do not install any mounting channel with the flat surface of the channel in contact with the HB Heating Module.

Fig 4

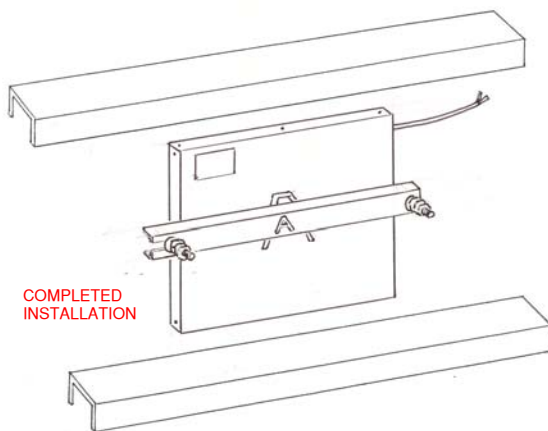

Apply a washer and one nut to each stud and tighten until the HB Heating Module is held lightly in position against the hopper surface. If necessary, carefully adjust the position of the HB Heating Module until it is symmetrically located with the mounting channel or channels (**Fig 4**).

Wrench tighten each nut until the HB Heating Module is clamped securely to hopper surface. Compression of the flexible heater face should take place, such that intimate contact between heater face and hopper surface is continually maintained.

Apply a second nut to each stud and tighten (**Fig 4**). Always apply the second nut to each stud to eliminate the potential of the first nut becoming loose due to hopper vibrations.

Repeat all of the procedures shown in Figures 1 through 4 on each HB Heating Module until the entire heating system is installed exactly as shown on the Heating System Layout drawing supplied by HTD. *If one or more HB Heating Modules cannot be fitted in the locations shown on the Heating System Layout drawing, consult HTD immediately.*

SYSTEM WIRING

Each HB Heating Module System is designed to operate on a specific power supply and each heating module within the system must be connected to the power supply exactly as shown in the system wiring diagram section of the Heating System Layout drawing. *Failure to follow this wiring procedure exactly will void all warranties and may lead to heater failures, unbalanced system loadings and system performance problems.* In event of questions or concerns, contact HTD immediately.

SYSTEM PROTECTION

Each HB Heating Module System must be protected by an appropriately sized fuse or circuit breaker. Recommended sizing of these overcurrent protection devices is shown on the Heating System Layout drawing.

GROUNDING

Fig 5



Following the installation of each HB Heating Module within the heating system as shown in the previous sections of this document, the heating system must be grounded to comply with all appropriate National, Federal and Local electrical codes and requirements.

As shown in **Fig 5**, each individual HB Heating Module is fitted with grounding brackets. There are two brackets on each heating module and they are normally located in diagonally opposite corners. Each bracket is permanently anchored to the heating module frame and supplied with a washer and screw.

As shown in **Fig 6**, each HB Heating Module can be individually grounded. The installer provides a suitably sized length of grounding wire with a crimped ring terminal that must be sized for use with the screw of the grounding bracket. The ring terminal is applied over the screw and washer, inserted into the grounding assembly and securely tightened. This procedure is repeated with every heating module within the system and the individual grounding wires are all routed to the nearest ground point to be secured and bonded.

Fig 6



Single ground wire attached to HB Heating Module

Alternatively, as shown in **Fig 7**, two or more HB Heating Modules can be interconnected with appropriately sized lengths of grounding wire to provide one complete grounding path that will ground all or part of the total heating system. In this instance, interconnecting ground wires must be fitted with two crimped ring terminals such that each end can be attached to the individual heating modules that are being linked together. The final run(s) of grounding wire are routed to the nearest ground point to be secured and bonded.

Grounding wire and ring terminals are not supplied by HTD as part of the heating system package.

Due to the elevated operating temperatures and corrosive environments associated with most flyash hopper heating applications, the use of a non jacketed, nickel plated or coated grounding wire is recommended. Grounding wire should be selected based upon the corrosive conditions of each application. The use of bare stranded copper grounding wire is not recommended.

Fig 7

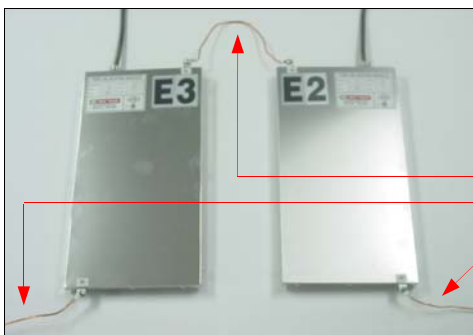

Interconnecting ground wires to link adjacent heating modules together throughout the system

TESTING

Before connecting each HB Heating Module into the Power Junction Box, thermally insulating the hopper and/or energizing the system, the installer should check the resistance (Ω) of each HB Heating Module using an Ohmmeter. Each reading should be compared with the corresponding nominal value shown on the Heating System Layout drawing. *Do not connect any HB Heating Module that has an ohm reading that is either 10% higher or 10% lower than the nominal value shown on the Heating System Layout drawing.* Record all readings for reference and comparison with readings taken during future routine maintenance checks.

Using a 1000 vdc Megger, the installer should measure the Insulation Resistance (IR) for each HB Heating Module. All readings greater than 1M Ω are acceptable. Record all acceptable readings for reference and comparison with readings taken during future routine maintenance checks. *Do not connect and / or energize any HB Heating Module that has an IR value less than 1M Ω and contact HTD to discuss the situation.*

The two above tests should also be repeated after the hopper has been thermally insulated and weather-proofed as described in the following section.

HOPPER INSULATION, DRAFT BARRIERS AND CONVECTION STOPS.

The kW sizing of each HB Heating Module System is designed to maintain a specified temperature under specific ambient and operating conditions. Sizing calculations have been based upon a specified type and thickness of thermal insulation being applied over the entire surface area of the hopper and all appurtenances. *To avoid system performance problems, always check that the specified type and thickness of thermal insulation is being used.* Consult HTD if there are any questions.

Whenever possible, hopper insulation should always be applied directly onto the face of the hopper stiffeners essentially forming a series of sealed cavities throughout the areas of the hopper that are being heated. This will prevent heat from being convected away from the lower areas of the hopper. In instances when the insulation cannot be attached directly to the hopper stiffeners the installer / insulation contractor must install draft barriers or convection stops at and completely around each stiffener and stiffener level within the hopper area being heated. Special attention must be paid to the corners where two stiffeners meet and any gaps left by the formation of the converging stiffeners must be plugged and sealed with insulation. Examples of typical draft barriers and convection stops are shown in Fig 8.(opposite) and specific details are also shown on HTD drawing D 096. Contact HTD if you do not have a copy of this drawing.

Failure to install draft barriers or convection stops may lead to reduced hopper temperatures and heating system performance problems.

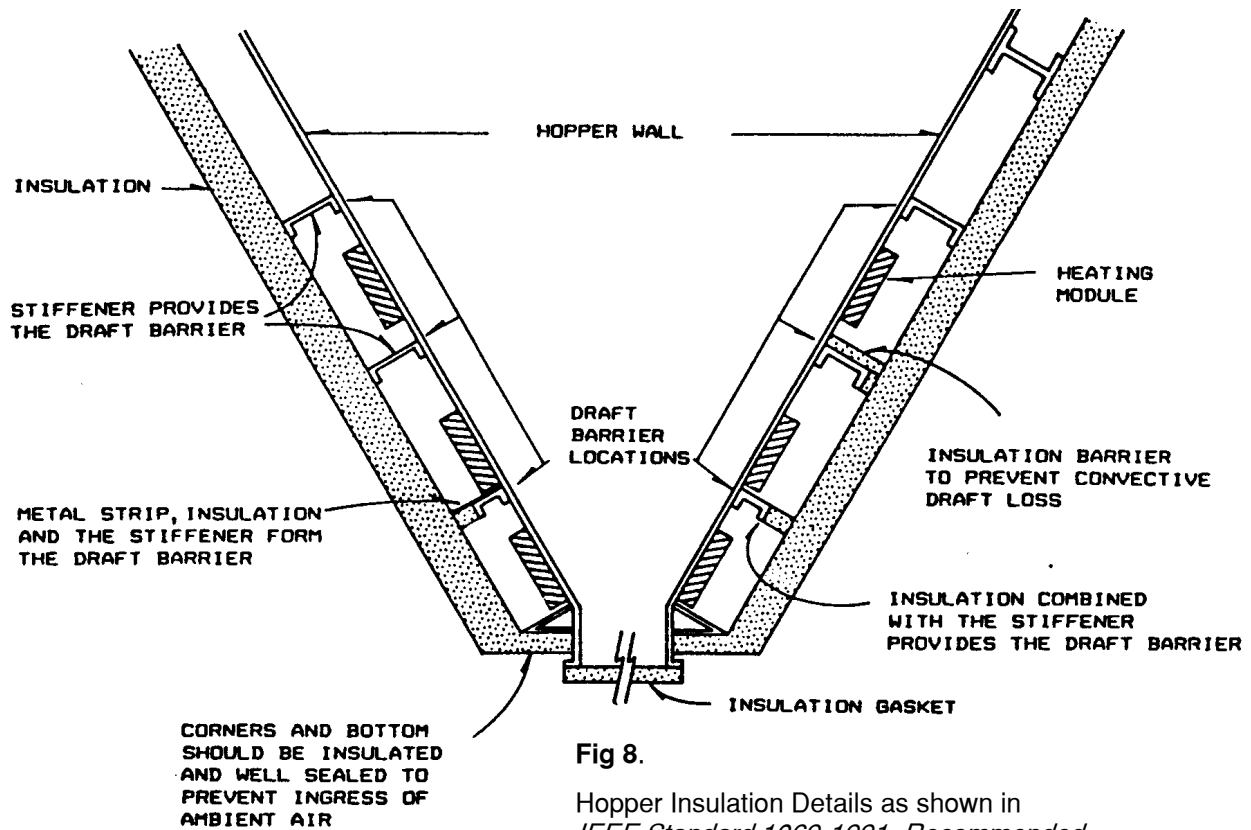

Fig 8.

Hopper Insulation Details as shown in *IEEE Standard 1069-1991, Recommended Practice for Precipitator and Baghouse Hopper Heating Systems.*

**HOPPER INSULATION
PROTECTION AND
WEATHER-PROOFING**

To avoid contamination, deterioration and significant reductions in efficiency, the thermal insulation applied to the hopper surfaces and appurtenances must also be protected from the ingress of water, moisture and dust by the application of a suitable weather-proofing barrier. Additionally, the HB Heating Module is third party approved by both FM and CSA for use in unclassified, dry, protected areas. Compliance with the requirements of these approvals requires that all exterior surfaces of the hopper insulation must be covered (aka lagged or clad) with a suitable weather-proof barrier.

The most common industry standard used to provide this essential climatic, environmental and heating system protection is metal cladding with corner flashings, corked joints and corking around all penetrations.

FLEXIBLE HEATERS

The installation of flexible throat and poke tube heaters is detailed in HTD Publication FLEXHTR INST-F-6/03.

Please contact HTD to request copies if this type of heater is included as part of your HB Heating Module System.



HTD Heat Trace, Incorporated
8 Bartles Corner Road
Unit #104, Flemington, NJ
USA 08822-5758

sales@htdheattrace.com
Voice - +1.908.788.5210
Fax - +1.908.788.5204
www.htdheattrace.com



HB HEATING MODULE SYSTEMS

INSTALLATION INSTRUCTIONS

FLEXIBLE HEATERS

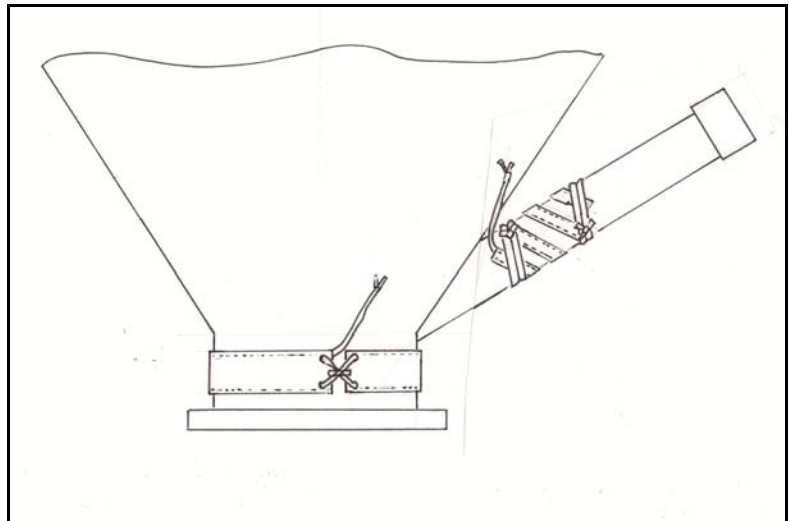

FLYASH HOPPER HEATING APPLICATIONS

SUPPLEMENTAL FLEXIBLE HEATERS.

Flyash hopper throats and poke tubes are significant heat sinks and, due to their physical location on the hopper, they are also critical areas that must be kept free from condensation. Condensation in these narrow sections of the hopper will promote the rapid build up of Flyash which can quickly lead to total pluggage of the hopper

Cylindrical hopper throat outlets and poke tubes cannot be effectively heated with heating modules. These areas can only be heated effectively with a "wraparound" type heater and HTD offers custom sized Flexible Heaters to provide the all important supplemental heat required at these critical locations.

Flexible Heaters are designed to be an integral part of the overall hopper heating system. Custom length cold lead cables are included such that all Flexible Heaters and HB Heating Modules connect to the power supply within the same Power Junction Box.

THROAT HEATERS.

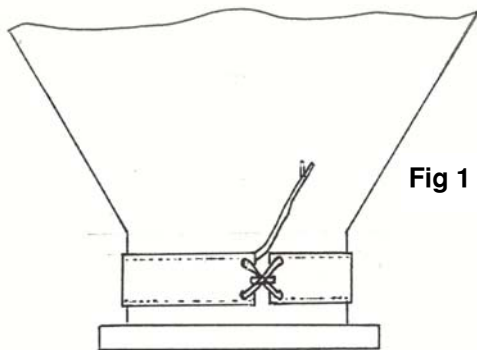

Wipe the throat area of the hopper to remove any water, moisture, rust or foreign material that may impede the installation of the Throat Heater. Wrap the Throat Heater around the hopper throat. Smooth out any wrinkles and creases. Thread 2 feet of fiberglass tying tape in a criss-cross pattern using the eyelits at each end of the Throat Heater. Pull on both ends of the tying tape to tension the the Throat Heater and hold it firmly in contact with the hopper throat. Tie both ends of the tying tape in a double knot to maintain permanent tension on the Throat Heater (Fig 1). Overwrap the Throat Heater with several wraps of tying tape until it is completely covered. Tie off the tying tape to complete the installation.

Do not overlap the Throat Heater upon itself and ensure that all wrinkles and creases are smoothed out before insulating the hopper.

POKE TUBE HEATERS.

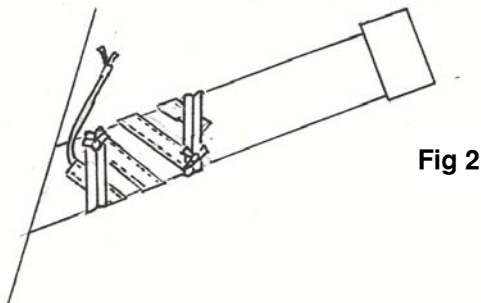

Wipe the poke tube to remove any water, moisture, dust, rust or foreign material that may impede the installation of the Poke Tube Heater. Spiral the Poke Tube Heater into position with 1 inch spacings between wraps. **Do not overlap the heater.** Smooth out any wrinkles and creases. Use one wrap of fiberglass tying tape to hold each end of the Poke Tube Heater in position. Tie the ends of the tying tape using double knots (Fig 2).

Overwrap the PokeTube Heater with tying tape until it is completely covered and tie off the tying tape to complete the installation.

Meter test all Flexible Heaters as shown in the HB Heating Module Installation Guide.

